

FLUID MECHANICS

TUTORIAL No.4

FLOW THROUGH POROUS PASSAGES

In this tutorial you will continue the work on laminar flow and develop Poiseuille's equation to the form known as the Carman - Kozeny equation. This equation is used to predict the flow rate through porous passages such as filter, filter beds and fluidised beds in combustion chambers.

On completion of this tutorial you should be able to do the following.

- Derive the Carman - Kozeny equation.
- Solve problems involving the flow of fluids through a porous material.

In order to do this tutorial you must be familiar with Poiseuille's equation for laminar flow and this is covered in tutorial 1.

FLOW THROUGH POROUS PASSAGES

The following are examples where porous flow occurs.

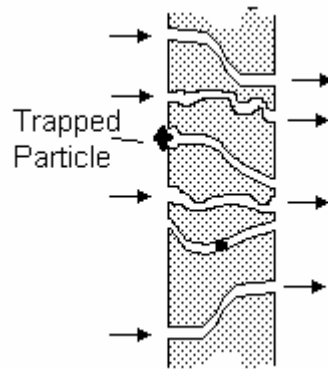

A filter element made of thick sintered particles. This might be a cylinder with radial flow.

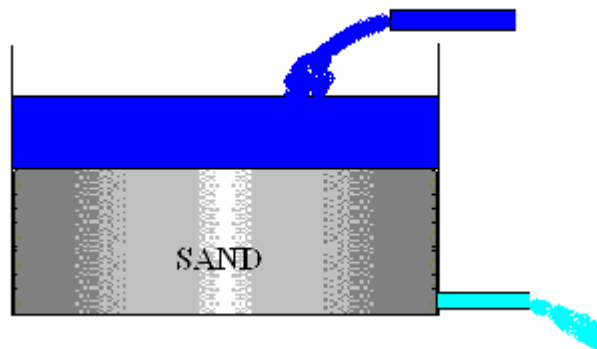

A sand bed filter for cleaning water. The water percolates down through the filter though long tortuous passages. The depth of water on top of the filter governs the rate at which the water is forced through.

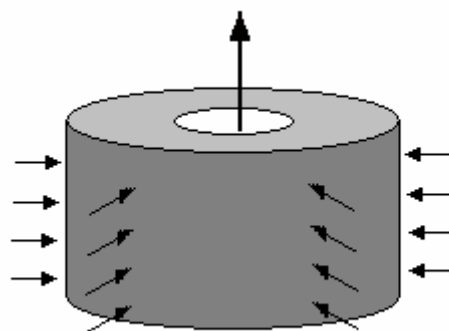

A layer of rock through which water, gas or oil might seep. This is similar to a radial flow filter but on a much larger scale.

When a fluid passes through a porous material, it flows through long thin tortuous passages of varying cross section. The problem is how to calculate the flow rate based on nominal thickness of the layer. This was tackled by Kozeny and later by Carman. The result is a formula, which gives a mean velocity of flow in the direction at right angles to the layer plane in terms of its thickness and other parameters.

The passage between the particles is so small that the velocity in them is small and the flow is well and truly laminar.

Poiseuille's Equation for laminar flow states $\Delta p/l = -32 \mu u'/D^2$.

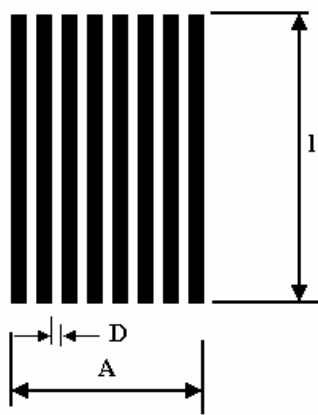

Figure 1

Kozeny modelled the layer as many small capillary tubes of diameter D making up a layer of cross sectional area A . The actual cross sectional area for the flow path is A' . The difference is the area of the solid material.

The ratio is $\epsilon = A'/A$ and this is known as the **porosity of the material**. The volume flow rate through the layer is Q .

Kozeny used the notion that $Q = Au$ where u is the mean velocity at right angles to the layer.

The volume flow rate is also $Q = A'u'$ where u' is the mean velocity in the tube.

Equating $u' = uA/A'$

$\epsilon = \text{void fraction} = A'/A$ $u' = u/\epsilon$.

Carman modified this formula when he realised that the actual velocity inside the tubes must be proportionally larger because the actual length is greater than the layer thickness. It follows that

$$u' = \frac{ul'}{\epsilon l}$$

where l is the layer thickness and l' the mean length of the passages. Substituting this in Poiseuille's Equation gives :

$$\frac{\Delta p}{l} = -\frac{32\mu ul'}{\epsilon l D^2}$$

rearranging $\frac{\Delta p}{l} = -\frac{32\mu ul'}{l\epsilon D^2}$

This is usually expressed as a pressure gradient in the direction of the mean flow (say x) and it becomes :

$$\frac{dp}{dx} = -\frac{32\mu ul'}{l\epsilon D^2} \dots\dots\dots(1)$$

A_s = csa of the solid

A' = csa of the tubes

A = csa of the layer = $A' + A_s$.

$$\varepsilon = \frac{A'}{A} = \frac{A'}{A' + A_s}$$

Multiply top and bottom by thye length l and the areas become volumes so

$$\varepsilon = \frac{Q'}{Q' + Q_s}$$

where Q' is the volume of the tubes and Q_s is the volume of the solid.

$$Q' = \varepsilon(Q' + Q_s)$$

$$Q - Q' = Q_s = Q - Q \frac{Q'}{Q} = Q - \varepsilon Q = Q(1 - \varepsilon)$$

$$Q_s = Q(1 - \varepsilon)$$

$$Q = \frac{Q_s}{(1 - \varepsilon)} = Q' + Q_s$$

$$Q' = \frac{\varepsilon Q_s}{(1 - \varepsilon)}$$

S = Surface Area of the tubes . Divide both sides by S $\frac{Q'}{S} = \frac{\varepsilon Q_s}{S(1 - \varepsilon)}$

Q' is made up of tubes diameter D and length l' so $Q' = \frac{n\pi D^2 l'}{4}$

and $S = n\pi D l'$ where n is the number of tubes which cancels when these are substituted into the formula. This results in : $D = \frac{4\varepsilon Q_s}{S(1 - \varepsilon)}$

Next we consider the solid as made up of spherical particles of mean diameter d_s .

S = surface area of tubes but also the surface area of the solid particles.

Hence $Q_s = \frac{\pi d_s^3}{6}$ and $S = \pi d_s^2$ and $\frac{Q_s}{S} = \frac{d_s}{6}$

It follows that $D = \frac{2\varepsilon d_s}{3(1 - \varepsilon)}$

Substitute this into equation (1) and : $\frac{dp}{dx} = -\frac{72\mu l'(1 - \varepsilon)^2}{l d_s^2 \varepsilon^3}$

Research has shown that (l'/l) is about 2.5 hence : $\frac{dp}{dx} = -\frac{180\mu l(1 - \varepsilon)^2}{d_s^2 \varepsilon^3}$

This is the Carman- Kozeny.

WORKED EXAMPLE No.1

Water is filtered through a sand bed 150 mm thick. The depth of water on top of the bed is 120 mm. The porosity ϵ is 0.4 and the mean particle diameter is 0.25 mm. The dynamic viscosity is 0.89 cP and the density is 998 kg/m³.

Calculate the flow rate per square metre of area.

SOLUTION

The pressure difference across the sand bed is assumed to be the head of water since atmospheric pressure acts on top of the water and at the bottom of the bed.

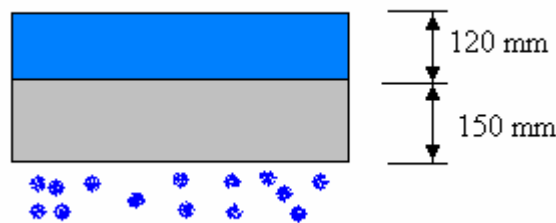

First convert the head into pressure difference.

$$\Delta p = \rho g(h_2 - h_1) = \{0 - (998 \times 9.81 \times 0.12)\} = -1174.8 \text{ Pa.}$$

The length of the bed (L) is 120 mm.

Assume that $dp/dx = \Delta p/L$ The dynamic viscosity is $0.89 \times 10^{-3} \text{ Ns/m}^2$.

Using the Carman- Kozeny equation where the pressure gradient is assumed to be linear.

$$\frac{dp}{dx} = -\frac{180\mu u(1-\epsilon)^2}{d_s^2 \epsilon^3}$$

$$\frac{dp}{dx} = -\frac{1174.8}{0.12} = -\frac{180 \times 0.89 \times 10^{-3} u (1-0.4)^2}{0.25 \times 10^{-3} \times 0.4^3}$$

$$7832.3 = 14418000u$$

$$u = 0.543 \times 10^{-3} \text{ m/s}$$

$$Q = 0.543 \times 10^{-3} \text{ m}^3 / \text{s per square meter of area.}$$

WORKED EXAMPLE No.2

Calculate the flow rate through a filter 70 mm outside diameter and 40 mm inside diameter and 100 mm long given that the pressure on the outside is 20 kPa greater than on the inside. The mean particle diameter d is 0.04 mm and the void fraction is 0.3. The dynamic viscosity is 0.06 N s/m².

SOLUTION

The flow is radial so $-dp/dx = dp/dr$ since radius increases in the opposite sense to x in the derivation. The equation may be written as :

$$\frac{dp}{dx} = -\frac{180\mu u(1-\varepsilon)^2}{d_s^2 \varepsilon^3}$$

r is the radius. Putting in values:

$$\frac{dp}{dr} = \frac{180 \times 0.06 u (1-0.3)^2}{0.00004^2 \times 0.3^3} = 122.5 \times 10^9 u$$

Consider an elementary cylinder through which the oil flows. The velocity normal to the surface is

$$u = \frac{Q}{2\pi L r} = \frac{Q}{2\pi \times 0.1 x r} = 1.591 Q r^{-1}$$

hence:

$$dp = 122.5 \times 10^9 \times 1.591 Q r^{-1} dr = 194.8975 Q r^{-1} dr$$

Integrating between the outside and inside radius yields:

$$p = 194.89 Q \ln\left(\frac{R_o}{R_i}\right)$$

$$p = 20000 = 194.89 Q \ln\left(\frac{35}{20}\right)$$

$$Q = 183.3 \times 10^9 m^3 / s = 183.3 mm^3 / s$$

SELF ASSESSMENT EXERCISE No.1

Q.1

Outline briefly the derivation of the Carman-Kozeny equation.

$$\frac{dp}{dl} = -\frac{180\mu u(1-\varepsilon)^2}{d_s^2 \varepsilon^3}$$

dp/dl is the pressure gradient, μ is the fluid viscosity, u is the superficial velocity, d_s is the particle diameter and ε is the void fraction.

A cartridge filter consists of an annular piece of material of length 150 mm and internal diameter and external diameters 10 mm and 20 mm. Water at 25°C flows radially inwards under the influence of a pressure difference of 0.1 bar. Determine the volumetric flow rate. (21.53 cm³/s)

For the filter material take $d = 0.05$ mm and $\varepsilon = 0.35$.

$\mu = 0.89 \times 10^{-3}$ N s/m² and $\rho = 997$ kg/m³.

Q.2

(a) Discuss the assumptions leading to the equation of horizontal viscous flow through a packed bed

$$\frac{dp}{dL} = -\frac{180\mu u(1-\varepsilon)^2}{d_s^2 \varepsilon^3}$$

where Δp is the pressure drop across a bed of depth L , void fraction ε and effective particle diameter d . u is the approach velocity and μ is the viscosity of the fluid.

(b) Water percolates downwards through a sand filter of thickness 15 mm, consisting of sand grains of effective diameter 0.3 mm and void fraction 0.45. The depth of the effectively stagnant clear water above the filter is 20 mm and the pressure at the base of the filter is atmospheric. Calculate the volumetric flow rate per m² of filter. (2.2 dm³/s)

(Note the density and viscosity of water are given in the instructions on all exams papers)

$\mu = 0.89 \times 10^{-3}$ N s/m² and $\rho = 997$ kg/m³

Q3.

Oil is extracted from a horizontal oil-bearing stratum of thickness 15 m into a vertical bore hole of radius 0.18 m. Find the rate of extraction of the oil if the pressure in the bore-hole is 250 bar and the pressure 300 m from the bore hole is 350 bar.

Take $d = 0.05$ mm, $\epsilon = 0.30$ and $\mu = 5.0 \times 10^{-3}$ N s/m².